

Hot Dog Roller Grills

Instruction Manual

Model #8023, Model #8024 and Model #8025
Model #8023SL, Model #8024SL and Model #8025SL









Model #8023 shown

 **GOLD MEDAL**®
FUNFOOD EQUIPMENT AND SUPPLIES

Table of Contents

I.	Safety Precautions.....	3
II.	Installation Instructions.....	4
III.	Operating Instructions.....	4
IV.	Cleaning Instructions.....	4
V.	Maintenance.....	5
VI.	System Parts Location Guide.....	6-7
VII.	Ordering Spare Parts.....	8
VIII.	Electrical Schematic.....	9
IX.	Warranty.....	10

SAFETY PRECAUTIONS

	<p style="text-align: center;">⚠ DANGER</p> <p>Machine MUST be properly grounded to prevent electrical shock to personnel. Failure to do so could result in serious injury or death. Do NOT immerse any part of this equipment in water. Always unplug the equipment before cleaning or servicing. Do not use excessive water when cleaning.</p>
	<p style="text-align: center;">⚠ WARNING</p> <p>NEVER put your fingers or any object into the heating area. We do NOT assume any liability for injury due to careless handling or operation of this equipment.</p>
	<p style="text-align: center;">⚠ WARNING</p> <p>ALWAYS wear safety glasses when servicing this equipment.</p>
	<p style="text-align: center;">⚠ WARNING</p> <p>Any alterations to this equipment will void the warranty and may cause a dangerous situation. NEVER make alterations to the equipment. Make sure all machine switches are in the off position before plugging the equipment into the receptacle.</p>
	<p style="text-align: center;">⚠ CAUTION</p> <p>This equipment is sold for commercial use only. Only personnel that are trained and familiar with the equipment should operate the equipment. Carefully read all installation, and operating instructions before operating the equipment.</p>
	<p style="text-align: center;">⚠ CAUTION</p> <p>This machine is NOT to be operated by minors. Minors are classified as anyone under the age of 18.</p>

NOTE

The information, specifications and illustrations contained in this manual represent the latest data available at time of publication. Right is reserved to make changes as required at the discretion of Gold Medal Products Company without notice.

INSTALLATION INSTRUCTIONS

CHECKING SHIPMENT

Unpack carton and check thoroughly for any damage which may have occurred during transit. Damage claims should be filed immediately with the transportation company. Gold Medal Products is not responsible for damage that may occur in transit.

ELECTRICAL REQUIREMENTS



Your Hot Dog Roller Grill requires a 120 volt/60 cycle/15 amp outlet, and should be operated on a dedicated line. Make sure to have a qualified electrician supply the proper electrical requirements before plugging the machine into an outlet.

OPERATING PROCEDURES

1. Place hot dogs on rollers. Turn heat to designated temperature. Left knob controls the heat of one set of five (5) rollers and the right controls the other set of five (5) rollers.
2. For low heat, set control(s) to LOW using one or both sets of rollers. For high capacity, set control(s) to MEDIUM or HIGH using both sets of rollers.

CARE AND CLEANING INSTRUCTIONS

Although corrosion resistant, stainless steel should be cleaned daily to prevent pitting. Do NOT use anything abrasive for cleaning (e.g. steel wool).

1. !!! UNPLUG THE POWER CORD FROM THE OUTLET !!!
2. Remove any remaining hot dogs from rollers.
3. Remove drip pans and clean thoroughly.
4. Use a mild detergent, soap and water, or soda-water to clean the roller grill. Rinse after washing and dry thoroughly before using.
5. When unit has been thoroughly cleaned and dried, reinsert drip pans beneath the rollers.
6. The unit is now cleaned and ready for operation, and it is safe to plug it back in.

MAINTENANCE INSTRUCTIONS

	⚠ CAUTION
	THE FOLLOWING SECTIONS OF THIS MANUAL ARE INTENDED ONLY FOR QUALIFIED SERVICE PERSONNEL WHO ARE FAMILIAR WITH ELECTRICAL EQUIPMENT. THESE ARE NOT INTENDED FOR THE OPERATOR.

	⚠ WARNING
	Adequate eye protection must be used when servicing this equipment to prevent the possibility of injury.

	⚠ DANGER
	Machine MUST be properly grounded to prevent electrical shock to personnel. Failure to do so could result in serious injury or death. Do NOT immerse any part of this equipment in water. Always unplug the equipment before cleaning or servicing. Do not use excessive water when cleaning.

System Parts Location Guide

8023-Medium Roller Assembly (10) p/n 88232, 8024-Short Roller Assy. p/n 88231. 8025-Long Roller Assy. p/n 88233

Teflon Bearing (20) p/n 87589

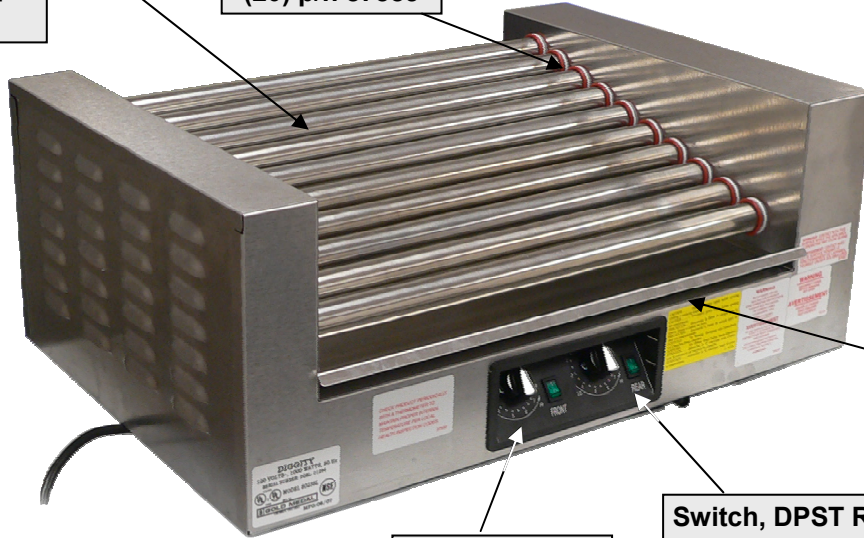

**8023-Drip Pan p/n 87646
8024-Drip Pan p/n 87606
8025-Drip Pan p/n 87636**

Switch, DPST Rocker (2) p/n 42532

Knob, Control (2) p/n 38389

**8023-Bottom Cover p/n 87647
8024-Bottom Cover p/n 87602
8025-Bottom Cover p/n 87634**

Strain Relief #SR-10-2 p/n 87163

End Cover (2) p/n 87601

Lead-In Cord 15A Plug p/n 22038

Crutch Tip (4) p/n 49123

Glide Feet (4) p/n 47328

Motor, 120V CW
p/n 87531
(Gray Fan)

Heat Control,
Minidogeroo
(2) p/n 87297

Switch, DPST Rocker
(2) p/n 42532

Motor, 120V
CCW p/n 87532
(Black Fan)

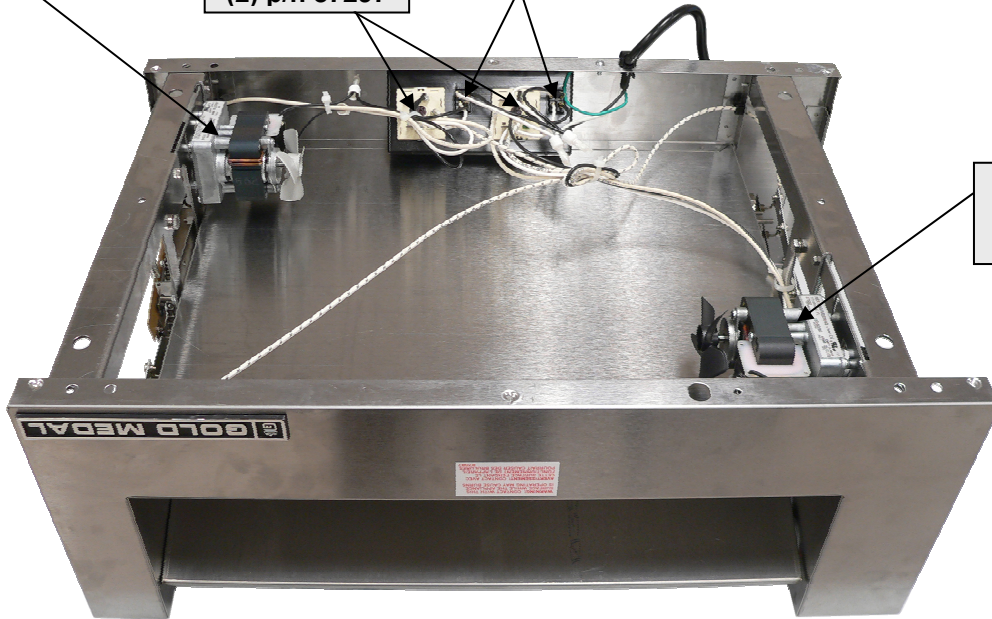

Support, Element
(2) p/n 87900

Positraction
Sprocket (8)
p/n 87988

Lower Drive
Chain p/n 87590

Master Link Drive
Chain (2) p/n 87044

Sprocket, Drive
(2) p/n 87353

Insulator Board
(2) p/n 88194

Conductor Plate
(4) p/n 87898

Upper Drive
Chain p/n 87591

#10 Flat Washer
St. Stl. p/n 12178

Idler Pivot
p/n 83106

Idler Bracket
p/n 68707

Model # 8023, 8024, 8025,
8023SL, 8024SL, 8025SL

Chain Idler Assy. (2)
p/n 68708
This assembly includes
all chain idler parts
illustrated.

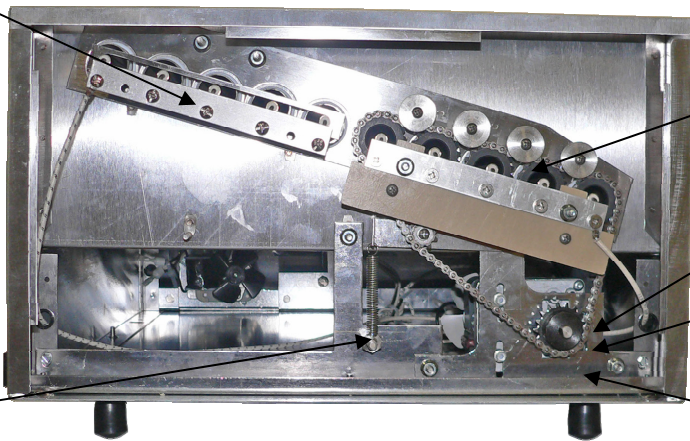

Spring p/n 68734

90W Heat Element (10)
(p/n 88123 for 8023)
(p/n 87376 for 8024)
(125W Heat Element p/n
88236 for 8025)

1/4 - 20 x 1/2 Hex Head
Bolt p/n 14821

Med Split Lock
Washer 1/4 p/n 74526

Spring Pivot
p/n 83107

8-32 x 3/4 Phil Pan
SMS p/n 87255

Idler Sprocket
p/n 69824

ORDERING SPARE PARTS

1. Identify the needed part by checking it against the photos, illustrations, and/or the parts list.
2. When ordering, please include part number, part name, and quantity needed.
3. Please include your model name, serial number, and date of manufacture (located on the machine nameplate) with your order.
4. Address all parts orders to:

Bruce's Entertainment
(661) 257-4260

WIRING DIAGRAM

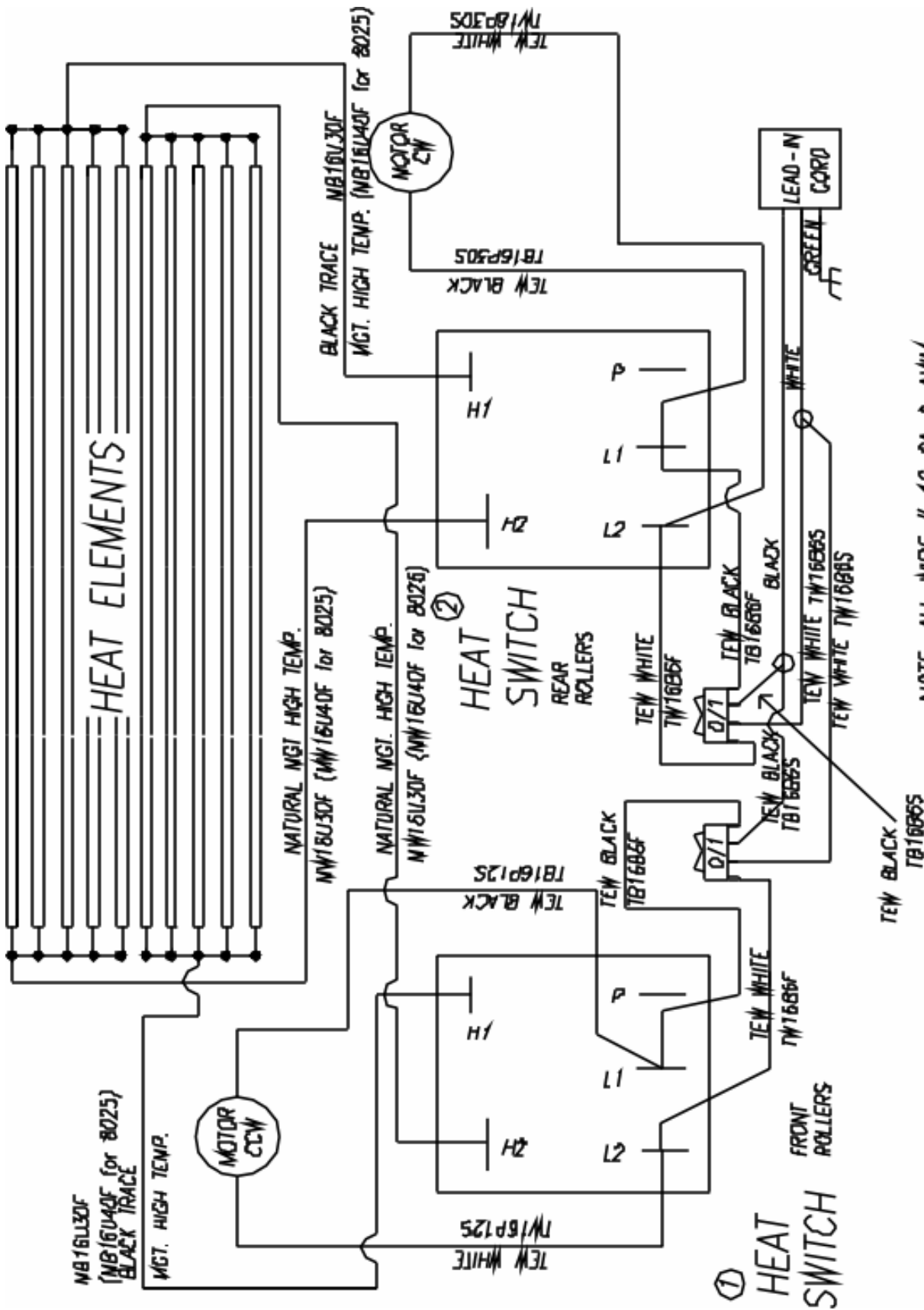

NOTE: ALL WIRE # 16 GA & AWG
 RATED 90° OR 105° C WITH
 1/32 THERMOPLASTIC INSULATION
 UNLESS OTHERWISE NOTED

WARRANTY

WE WARRANT to the original purchaser the Gold Medal equipment sold by us to be free from defects in material or workmanship under normal use and service. Our obligation under this warranty shall be limited to the repair or replacement of any defective part for a period of six (6) months from the date of sale to the Original Purchaser with regard to labor and two (2) years with regard to parts and does not cover damage to the equipment caused by accident, alteration, improper use, voltage, abuse, or failure to follow instructions.

THIS WARRANTY IS IN LIEU OF ALL OTHER WARRANTIES EXPRESSED OR IMPLIED, AND OF ALL OTHER OBLIGATIONS OR LIABILITIES ON OUR PART, INCLUDING THE IMPLIED WARRANTY OF MERCHANTABILITY. THERE ARE NO WARRANTIES WHICH EXTEND BEYOND THE DESCRIPTION ON THE FACE HEREOF. We neither assume, nor authorize any other person to assume for us, any other obligation or liability in connection with the sale of said GOLD MEDAL equipment or any part thereof.

The term "Original Purchaser" as used in this warranty shall be deemed to mean that person, firm, association, or corporation who was billed by the GOLD MEDAL PRODUCTS COMPANY, or their authorized distributor for the equipment.

THIS WARRANTY HAS NO EFFECT AND IS VOID UNLESS THE ORIGINAL PURCHASER FIRST CALLS GOLD MEDAL PRODUCTS COMPANY AT 1-800-543-0862 TO DISCUSS WITH OUR SERVICE REPRESENTATIVE THE EQUIPMENT PROBLEM, AND, IF NECESSARY, FOR INSTRUCTIONS CONCERNING THE REPAIR OR REPLACEMENT OF PARTS.

NOTE: This equipment is manufactured and sold for commercial use only.



© The text, descriptions, graphics and other material in this publication are the proprietary and exclusive property of Gold Medal Products Company and shall not be used, copied, reproduced, reprinted or published in any fashion, including website display, without its express written consent.

